

2.1



HSD series

Orbital hydraulic motor

The HSD series orbital hydraulic motor, it is a lowspeed and high-torque hydraulic motor, the end face distribution makes it to have characteristics of high working pressure, low starting pressure, high efficiency and high reliability.

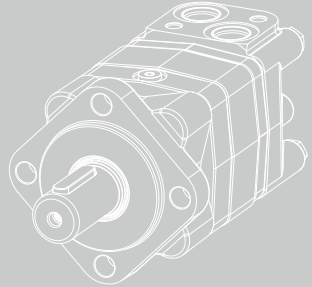

Contents

Overview	02
Advantages	02
Standard structure	02
Specification	03
Displacement performance	04-08
Installation size	09-12
Shaft end dimensions	13-16
Allowable shaft load/bearing curve	17
Permissible shaft seal pressure	17
Hydraulic diagram	17
Rotation direction	17
Ordering information	18



Bearingless motor

Standard mount

Overview

The HSD series orbital hydraulic motor, it is a low-speed and high-torque hydraulic motor, the end face distribution makes it to have characteristics of high working pressure, low starting pressure, high efficiency and high reliability. Customized product can be developed by different application requirement.

Advantages

- Using tapered roller bearing structure, can support larger axial and radial load.
- Advanced disc valve structure, high distribution accuracy, strong automatic compensation ability after wear, to ensure high volumetric efficiency, long life, efficient and stable work.
- Various displacements and installation dimensions are available.

Standard structure

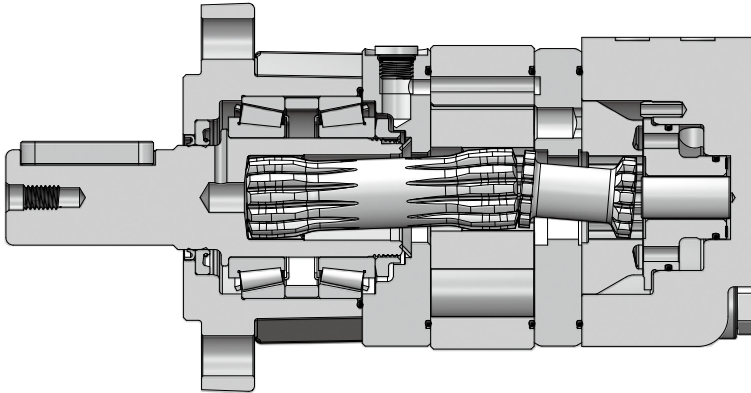

P-0029

Specification

Type		80	100	125	160	200	230	250	315	400	500
Displacement (cm ³ /rev.)		80.2	99.6	124.9	159.2	199.4	232.1	249.3	314.0	391.9	488.3
Max.speed (rpm)	Continuous	807	746	602	472	373	323	298	238	191	156
	Intermittent	995	897	723	563	449	386	359	284	231	187
Max.torque (Nm)	Continuous	244	301	378	488	608	654	722	823	864	853
	Intermittent	315	388	492	599	722	813	874	997	992	992
Max.output (kW)	Continuous	15.5	18.0	18.0	16.5	16.5	13.8	14.5	15.0	11.0	9
	Intermittent	19.5	22.5	22.5	23.0	22.0	17.2	18.0	17.0	12.5	10.5
Max.pressure drop (bar)	Continuous	210	210	210	210	210	200	200	200	160	120
	Intermittent	275	275	275	260	250	250	250	240	190	140
	Peak	295	295	295	280	270	270	270	260	210	160
Max.flow (L/min)	Continuous	65	75	75	75	75	75	75	75	75	75
	Intermittent	80	90	90	90	90	90	90	90	90	90
Max.no-load starting pressure (bar)		12	10	10	8	8	8	8	8	8	8
Min.starting torque (Nm)	Max.continuous	188	233	292	373	467	517	556	700	699	653
	Max.Intermittent	246	305	383	461	556	647	695	840	830	762

T - 0041

- Intermittent working condition: The working time should be less than 6 seconds per minute under the intermittent working condition.
- Peak differential pressure: At peak differential pressure, the operating time is less than 0.6 seconds per minute.
- It is not recommended for the motor to work at simultaneous maximum torque and maximum speed.
- The filtration standard of ISO 4406 cleaning standard 20/18/15 is recommended.
- High quality anti-wear hydraulic fluids are recommended.
- When the temperature is 50°, the minimum viscosity of the oil is recommended to be 20mm²/s.
- The recommended maximum operating temperature is 82°C .
- To assure best motor life, run motor 10-15 minutes in low speed high torque mode at approximately 50% of continuous pressure and 50% of continuous flow.

Displacement performance

		Pressure(bar)					Max.Cont		Max.Inter	
80		30	70	105	140	175	210	225	250	275
80.2 cm ³ /rev.		Torque(Nm), Speed(rpm)								
Flow (L/min)	5	30	77	115	155	195	223			
		61	59	54	44	37	32			
10	27	72	114	156	195	244	246	269		
	123	117	110	100	88	73	67	60		
20	25	70	114	154	193	233	249	279	305	
	245	239	234	222	206	185	177	160	147	
30	23	69	109	151	197	230	250	278	315	
	367	360	353	343	323	302	295	279	256	
40	25	70	105	146	189	228	248	277	307	
	494	485	477	469	448	425	419	399	385	
50		67	106	145	187	225	245			
		609	598	584	565	543	532			
Max.Cont	65		66	100	142	184	229	240		
			807	786	763	744	718	711		
Max.Inter	80		61	99	142	177				
			995	968	943	919				

Overall Efficiency: 70-100% 40-69% 0-39%

T - 0047

		Pressure(bar)					Max.Cont		Max.Inter	
100		35	70	105	140	175	210	225	250	275
99.6 cm ³ /rev.		Torque(Nm), Speed(rpm)								
Flow (L/min)	5	47	98	149	198	245	284	299		
		49	48	46	43	37	31	23		
10	47	96	148	198	250	298	317	351	375	
	100	97	94	89	84	76	71	61	49	
20	46	96	145	198	250	301	321	358	387	
	198	196	191	187	181	168	160	150	147	
30	45	95	146	196	246	297	322	358	388	
	299	297	294	289	279	263	261	248	229	
40	42	92	141	195	245	296	319	353	387	
	398	394	391	391	384	368	364	346	335	
50	37	90	138	190	242	297	315			
	497	492	491	485	483	467	459			
60	36	85	134	185	235	290	310			
	596	593	583	577	562	565	552			
Max.Cont	75	31	78	125	182	229	285	305		
		746	739	742	725	711	697	692		
Max.Inter	90		73	119	175	225				
			897	878	875	861				

Overall Efficiency: 70-100% 40-69% 0-39%

T - 0048

Displacement performance

		Pressure(bar)					Max.Cont		Max.Inter	
125		35	70	105	140	175	210	225	250	275
124.9cm ³ /rev.		Torque(Nm), Speed(rpm)								
Flow (L/min)	5	50	113	176	229	301	327			
		38	38	35	31	26	16			
10	49	113	176	241	300	352	376	412		
	79	77	74	67	60	48	45	37		
20	48	110	175	239	302	378	384	430	475	
	159	158	152	147	131	116	106	94	82	
30	47	110	171	237	299	365	392	437	475	
	240	236	233	224	213	192	184	169	153	
40	45	108	170	234	298	364	388	432	492	
	320	316	312	303	293	269	256	249	233	
50	41	101	167	235	297	365	389			
	401	395	387	381	363	348	343			
60	36	103	165	233	295	357	384			
	474	475	468	458	441	434	423			
Max.Cont	75	26	95	152	217	285	353	378		
		591	602	579	569	558	534	529		
Max.Inter	90		84	148	212	275				
			723	703	683	673				

Overall Efficiency: 70-100% 40-69% 0-39% T - 0049

		Pressure(bar)					Max.Cont		Max.Inter	
160		35	70	105	140	160	175	210	225	260
159.2cm ³ /rev.		Torque(Nm), Speed(rpm)								
Flow (L/min)	5	71	151	232	307	356	386			
		30	30	28	24	20	18			
10	72	151	230	311	355	385	460	489		
	63	63	58	54	47	41	34	32		
20	71	148	231	311	356	389	466	500		
	125	123	120	115	108	102	85	79		
30	67	145	226	308	355	389	488	501	599	
	187	186	183	178	170	165	145	136	112	
40	62	141	222	305	350	384	464	499	574	
	250	249	245	241	235	228	208	202	180	
50	59	134	216	297	344	378	457	491		
	311	308	305	297	293	287	264	259		
60	49	129	207	290	337	372	455	488		
	376	370	366	362	355	349	331	319		
Max.Cont	75	36	115	198	279	323	362	444	472	
		472	469	468	455	449	443	444	415	
Max.Inter	90	24	110	184	267	302				
		563	559	550	541	525				

Overall Efficiency: 70-100% 40-69% 0-39% T - 0050

Displacement performance

		Pressure(bar)						Max.Cont	Max.Inter	
		35	70	105	140	160	175	210	225	250
200		199.4cm ³ /rev.								
		Torque(Nm), Speed(rpm)								
Flow (L/min)	5	78 24	171 21	249 23	384 20					
	10	76 48	191 48	293 48	383 45	446 37	488 36	574 27		
Max.Cont	20	83 99	190 99	292 97	393 93	452 89	496 85	593 72	633 63	695 52
	30	81 149	187 148	289 146	390 146	455 139	492 134	608 120	634 112	701 97
Max.Inter	40	76 198	183 198	285 198	387 197	444 192	487 188	592 175	633 171	722 158
	50	61 249	177 248	278 247	379 245	439 242	479 235	584 229	626 221	
Max.Cont	60	52 298	167 294	268 293	372 293	427 286	475 279	571 264	612 257	
	75	42 373	155 378	257 373	354 371	410 363	454 355	558 340	603 329	
Max.Inter	90	27 449	141 446	240 448	339 437	400 431				

Overall Efficiency: 70-100% 40-69% 0-39% T - 0051

		Pressure(bar)						Max.Cont	Max.Inter	
		35	70	95	125	140	155	175	200	225
230		232.1cm ³ /rev.								
		Torque(Nm), Speed(rpm)								
Flow (L/min)	5	113 21	232 20	320 20						
	10	113 43	229 42	321 40	420 38	465 36	517 33	569 33	652 31	
Max.Cont	20	111 86	227 85	316 84	416 79	462 76	515 73	513 71	654 65	736 61
	30	109 129	222 125	310 123	412 119	462 115	514 115	510 111	657 101	735 99
Max.Inter	40	105 173	218 167	307 167	409 160	461 159	511 154	510 152	652 143	729 140
	50	98 217	213 214	298 215	405 204	447 204	500 196	504 200		
Max.Cont	60	89 260	213 257	291 254	400 248	442 246	497 240	498 241		
	75	77 323	192 323	274 319	390 312	428 312	483 306	482 305		
Max.Inter	90	57 386	173 385	258 384	364 381	411 374				

Overall Efficiency: 70-100% 40-69% 0-39% T - 0052

Displacement performance

		Pressure(bar)						Max.Cont		Max.Inter	
		35	70	95	125	140	155	175	200	225	250
250		249.3 cm ³ /rev.									
		Torque(Nm), Speed(rpm)									
Flow (L/min)	5	115 19									
	10	117 40	239 38	332 38	438 34	482 34	536 32	596 28			
Flow (L/min)	20	113 78	239 78	331 77	437 72	490 69	546 67	620 63	722 55	780 46	874 39
	30	111 120	237 119	330 118	437 115	490 113	544 110	618 103	704 93	787 80	
Flow (L/min)	40	106 159	231 157	322 154	430 154	487 154	538 149	624 145	703 134	791 124	
	50	102 200	223 195	320 196	430 196	479 192	531 192	610 186			
Flow (L/min)	60	91 239	216 238	311 240	416 237	471 235	522 231	596 225			
	75	79 298	206 295	292 294	406 293	453 291	507 285	580 276			
Max.Cont	75										
Max.Inter	90	59 357	185 358	273 359	385 354	423 351					

Overall Efficiency: 70-100% 40-69% 0-39%

T - 0053

		Pressure(bar)						Max.Cont		Max.Inter	
		35	70	100	120	140	160	175	200	225	240
315		314.0cm ³ /rev									
		Torque(Nm), Speed(rpm)									
Flow (L/min)	5	147 15	309 13	426 13							
	10	151 30	306 28	440 28	527 25	600 23	670 20				
Flow (L/min)	20	154 62	304 63	442 60	531 60	612 55	731 46				
	30	150 94	318 94	439 92	541 89	617 85	700 76	764 73	823 65	977 66	997 60
Flow (L/min)	40	144 127	303 127	448 125	532 121	647 117	756 111	826 105	903 95	940 98	
	50	127 160	297 158	442 156	533 153	639 149	754 144	809 139			
Flow (L/min)	60	125 187	285 191	436 187	525 186	633 182	744 174	809 168			
	75	99 238	266 237	406 237	502 234	601 226	706 222				
Max.Cont	75										
Max.Inter	90	68 283	238 284	388 284	479 281	572 276					

Overall Efficiency: 70-100% 40-69% 0-39%

T - 0054

Displacement performance

		Pressure(bar)						Max.Cont	Max.Inter	
		30	60	80	105	120	140	160	175	190
400		391.9cm ³ /rev.								
		Torque(Nm), Speed(rpm)								
Flow (L/min)	5	167 12	352 12							
	10	177 25	346 24	461 22	606 21					
	20	170 49	341 47	463 47	609 45	695 43	809 39	864 33	987 30	
	30	162 73	337 73	457 74	606 72	692 70	807 65	916 58	990 45	992 41
	40	153 98	328 99	445 98	593 96	683 97	799 90	912 83	982 69	
	50	143 124	318 124	437 124	576 122	668 121	788 116			
Max.Cont	60	133 151	301 148	420 148	566 146	653 144	775 141			
	75	101 191	277 186	393 184	540 184	629 182				
	Max.Inter	90	73 231	246 221	361 222	511 220				

Overall Efficiency: 70-100% 40-69% 0-39%

T - 0055

		Pressure(bar)					Max.Cont	Max.Inter
		25	50	80	90	105	120	140
500		488.3cm ³ /rev.						
		Torque(Nm), Speed(rpm)						
Flow (L/min)	10	189 18	355 18					
	20	176 40	354 39	571 37	646 34	760 31		
	30	164 59	343 57	564 55	636 54	742 51	853 48	992 38
	40	148 80	333 78	550 76	621 74	729 73	833 70	
	50	136 98	318 100	537 96	610 95	717 93	831 87	
	60	119 120	302 118	524 117	598 115	705 111		
Max.Cont	75	94 156	269 148	489 144	565 142	673 140		
	Max.Inter	90	56 177	237 187	455 174	528 172		

Torque (Nm):831
Speed (rpm):87

Overall Efficiency: 70-100% 40-69% 0-39%

T - 0056

Installation size

Port size

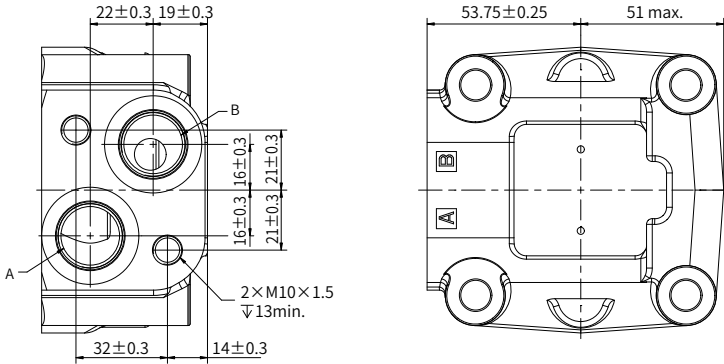

P - 0030

- Port size: **1** Main PortA, B: G1/2
Drain PortC: G1/4 **2** Main PortA, B: 7/8-14UNF
Drain PortC: 7/16-20UNF **3** Main PortA, B: M22×1.5
Drain PortC: M14×1.5

A3 2-HOLE, SAE A MOUNT

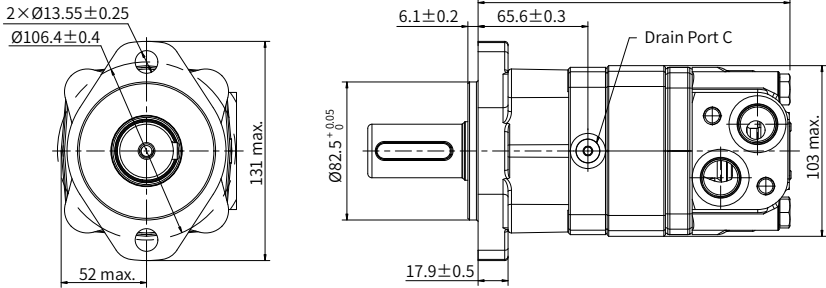

P - 0033

A2 4-HOLE, SAE A MOUNT

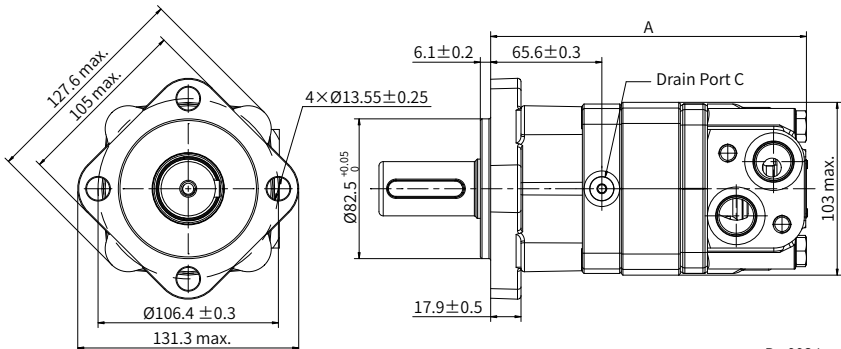

P - 0034

Installation size

B2 2-HOLE, SAE B MOUNT

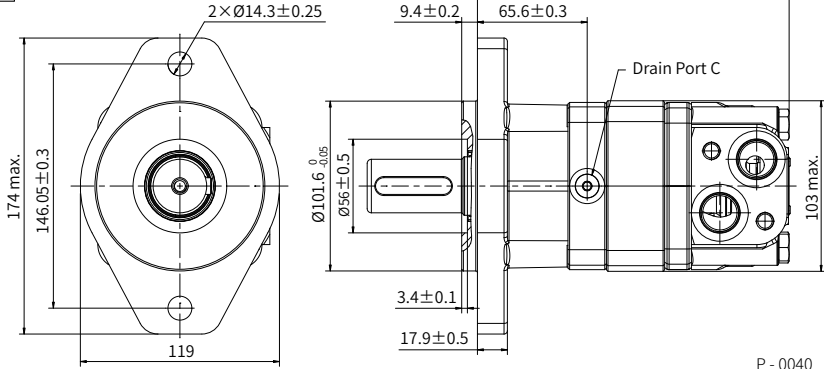

P - 0040

M0 6-HOLE, MAGNETO MOUNT

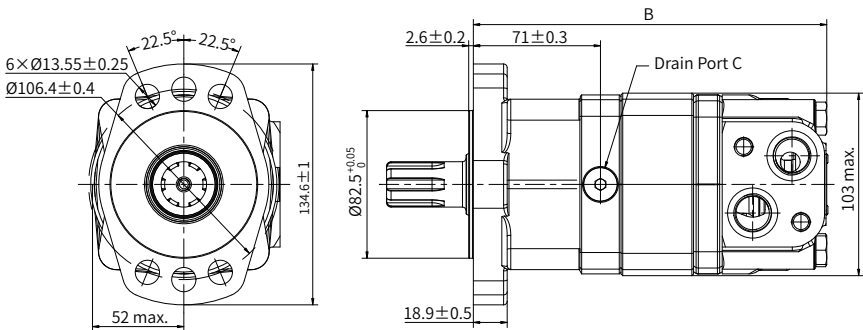

P - 0035

F1 SQUARE MOUNT

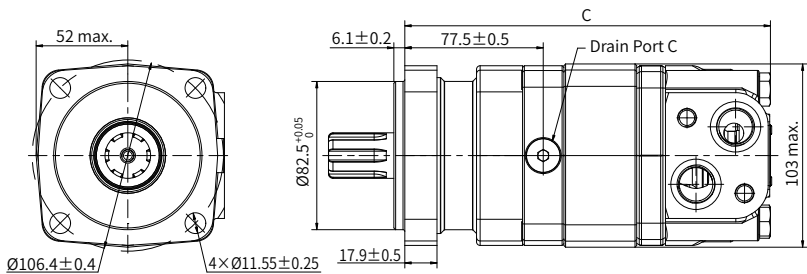

P - 0041

Installation size

B0 CIRCULAR FLANGE

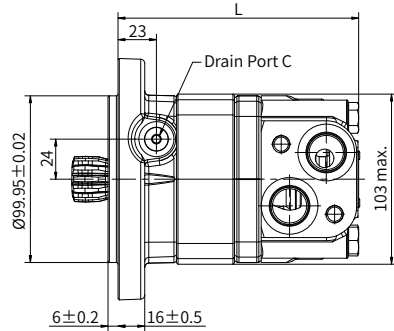
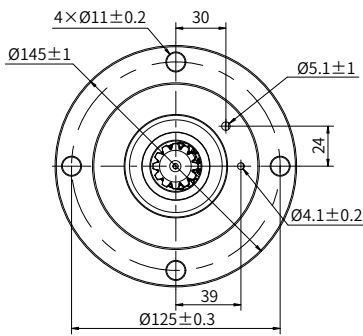

P - 0031

F0 SQUARE MOUNT

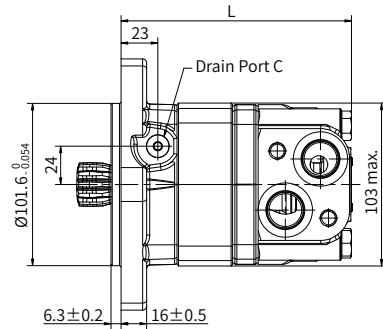
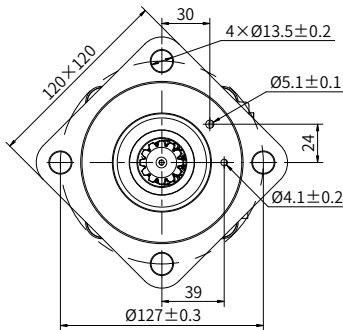

P - 0032

Displacement cm ³ /rev.	L mm	A mm	B mm	C mm
80	123.4	165.5	170.9	177.4
100	126.8	168.9	174.3	180.8
125	131.2	173.3	178.7	185.2
160	137.2	179.3	184.7	191.2
200	144.2	186.3	191.7	198.2
230	149.9	192.0	197.4	203.9
250	152.9	195.0	200.4	206.9
315	164.2	206.3	211.7	218.2
400	177.8	219.9	225.3	231.8
500	177.8	219.9	225.3	231.8

T - 0058

Note: Dimensions L, A, B, C are the length from the flange mounting surface to the rear end of the motor, and the tolerance is ± 0.61 mm.

Shaft end dimensions

R2

Ø22mm Spline 13-DP16/32, ANS B92.1 - 1996
 Max. Torque: 170Nm

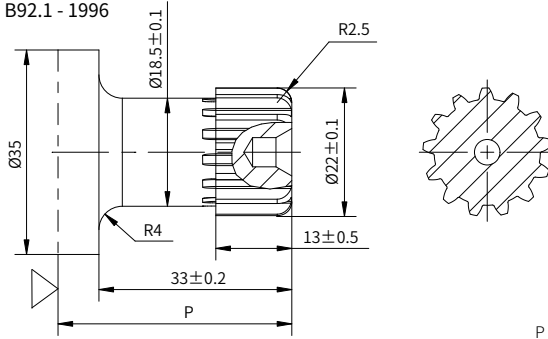

P - 0049

R1

Ø25.4mm Spline SAE 6B (B.S.2059)
 Max. Torque: 678Nm

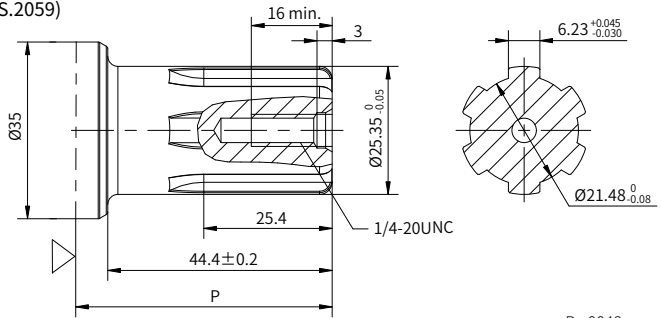

P - 0048

R4

Ø31.75mm Spline 14-DP12/24, ANS B92.1 - 1996
 Max. Torque: 881Nm

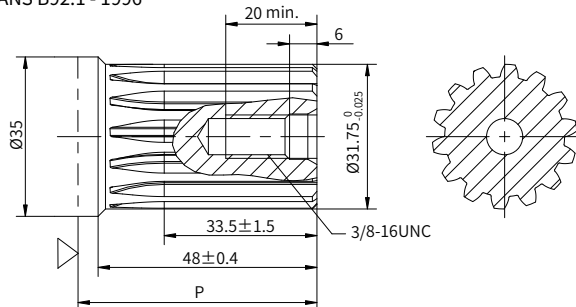

P - 0046

Shaft end dimensions

R5

Ø31.75mm Spline 14-DP12/24, ANS B92.1 - 1996
 Max. Torque: 881Nm

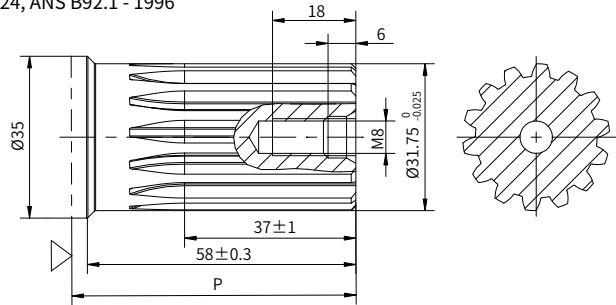

P - 0047

T2

Ø31.75mm Tapered
 Parallel key $7.96 \times 7.96 \times 31.75$
 Tightening torque $200 \pm 10\text{Nm}$
 Max. Torque: 881Nm

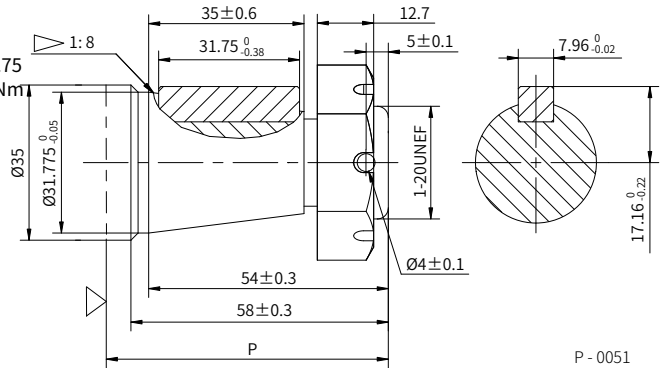

P - 0051

T8

Ø35mm Tapered
 Parallel key $6 \times 6 \times 20$
 Tightening torque $200 \pm 10\text{Nm}$
 Max. Torque: 881Nm

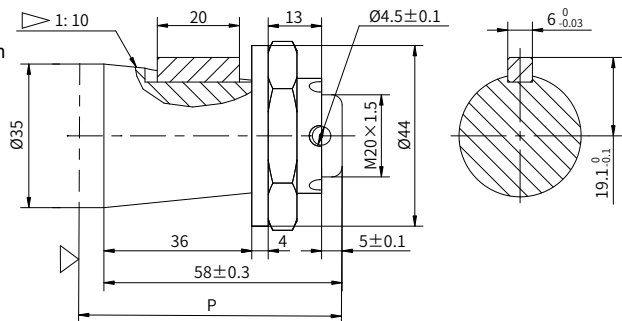

P - 0050

Shaft end dimensions

R8

Ø34.85mm Spline 6B PTO
DIN 9611 Form 1
Max. Torque: 881Nm

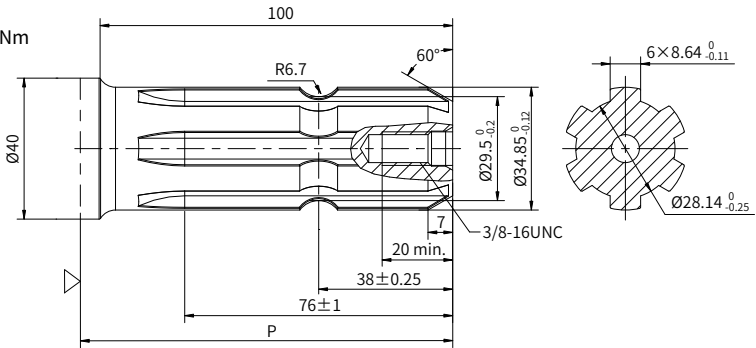

P - 0053

P mm	SAE Mount	Magneto Mount	Square Mount
S1	51.0	45.6	39.1
S5	56.0	50.6	44.1
S3	66.0	60.6	54.1
R2	41.0	35.6	29.1
R1	53.9	48.5	42.0
R4	56.0	50.6	44.1
R5	70.9	65.5	59.0
T2	66.0	60.6	54.1
T8	66.0	60.6	54.1
R8	108.0	102.6	96.1

T - 0064

Note: Dimension A is the overall distance from the flange mounting surface to the end of the shaft, and the tolerance is ± 0.97 mm.

Allowable shaft load/bearing curve

As shown in the figure, when the axial load is 0, the radial allowable load of the output shaft is related to the distance from the flange mounting surface to the load action point.

The solid line shows the allowable radial load of the bearing. It is based on L10 bearing life 2000 hrs at 100 RPM with rated output torque.

The dash line shows max radial shaft load. Any shaft load exceeding the values quoted in the curve will involve a risk of failure.

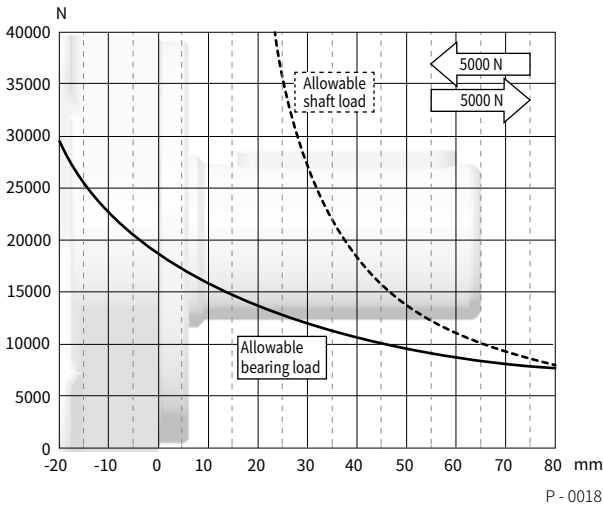

Hydraulic diagram

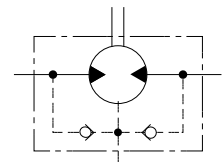

P - 0020

Permissible shaft seal pressure

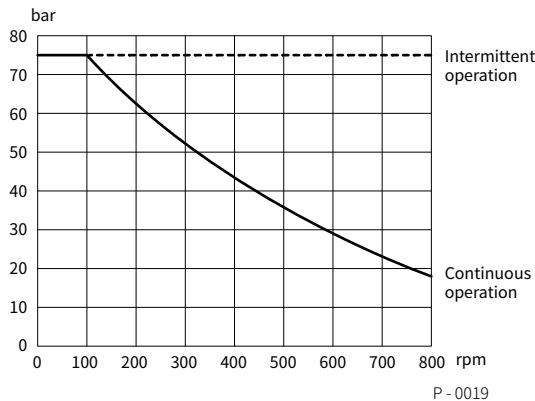

When case drain port is not working, the pressure on the output shaft seal is slightly higher than the pressure in the return line. When using a drain line, the pressure on the shaft seal of the output shaft is the same as the pressure in the drain line.

Rotation direction: CW

When facing the motor shaft extension direction, port A is high pressure oil, the output shaft rotates CW; Otherwise, it rotates CCW.

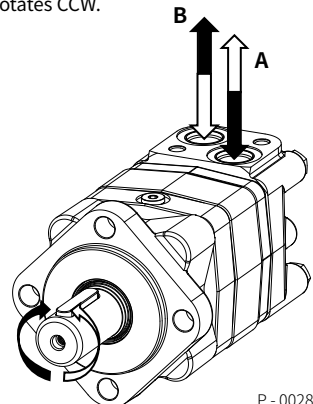

Ordering information

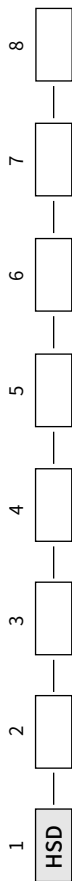

Pos.1	2	3	4	5	6	7	8		
Series code	Displacement	Mount	Port	Output shaft	Rotation direction	Paint option	Special features		
HSD	080	A3 SAE A 2 × Ø13.5 Mount Ø106.4, pilot Ø82.5 × 6.3	1 Port G1/2, Drain Port G1/4 2 Port 7/8-14UNF, Drain Port 7/16-20UNF 3 Port M22 × 1.5, Drain Port M14 × 1.5 T8 Ø35 Tapered, Parallel key 6 × 6 × 20 R8 Ø34.85 6B Spline PTO C1 Cardan	S1 Ø25.4 Straight, Parallel key 6.35 × 6.35 × 31.75 S5 Ø31.75 Straight, Parallel key 7.96 × 7.96 × 31.75 S3 Ø32 Straight, Parallel key 10 × 8 × 45 R2 Ø22 Spline 13-DP16/32 R1 Ø25.4, Spline SAE 6B R4 Ø31.75 Spline 14-DP12/24 R5 Ø31.75 Spline 14-DP12/24 T2 Ø31.75 Tapered, Parallel key 7.96 × 7.96 × 31.75 T8 Ø35 Tapered, Parallel key 6 × 6 × 20 R8 Ø34.85 6B Spline PTO C1 Cardan	A R	CW CCW	N B C	A F V S	
	100	A2 SAE A 4 × Ø13.5 Mount Ø106.4, pilot Ø82.5 × 6.1		No Paint	A	CW	N	A	
	125	B2 SAE B 2 × Ø14.3 Mount Ø106.4, pilot Ø101.6 × 9.4		Black	R	R	CCW	B	F
	160	M0 6 × Ø13.5 Magneto Mount Ø106.4, pilot Ø82.5 × 2.6		Hengli blue	R	R	CCW	C	V
	230	F1 4 × Ø11.55 Square Mount Ø106.4, pilot Ø82.5 × 6.1		Standard	R	R	CCW	C	F
	250	B0 4 × Ø11 Circular Flange Ø125, pilot Ø100 × 6		Free running	R	R	CCW	C	V
	315	F0 4 × Ø13.5 Square Mount Ø127, pilot Ø101.6 × 6.3		High temperature	R	R	CCW	C	V
	400			Low temperature	R	R	CCW	C	S
	500				R	R	CCW	C	S

Note: 1) The C1 shaft is only available for B0, F0 flanges.

2) When using the order information, the user can select the motor series, displacement, installation flange, port, shaft and other information. If the selected specification is not in the table or has special requirements, please contact us.

T - 0067