



3.1

## HM2F SERIES

### Bent-axial Piston Fixed Displacement Motor

HM2F series bent-axial piston fixed displacement motor is used in an open or closed circuit. The bent-axial structure ensures a larger displacement and a more compact structure under the same volume.

Apply to open or close circuit

Size: 90  
Nominal pressure (bar): 400  
Max pressure (bar): 450



### Contents

Technical Data	02
Type introduction	03-04
Section view	05
Principle	05
Installation size	
· HM2F Installation size	06
· Direction of rotation and oil flow direction	07
· Port details	07
· Input shaft type	07

### Features

- ◁ Higher pressure and higher speed
- ◁ High activation efficiency
- ◁ Optimized power-weight ratio
- ◁ High torque and long service life
- ◁ Superior performance in low speed operation provides excellent controllability
- ◁ Suitable for engineering machinery and general industrial vehicles

## Technical Data

Feature		90
Max. Displacement (cc/rev)		90.5
Direction of rotation		Clockwise, Counter clockwise
Rotation speed	Rated (rpm)	4500
	Max. (rpm)	5000
Rated pressure (bar)		400
Max. pressure (bar)		450
Theoretical output torque (N·m)		576 @ $\Delta P=400$ bar
Max. Flow (L/min)		407
Moment of inertia (kg·m <sup>2</sup> )		0.0058
Weight (kg)		24.7
Volume in the case (L)		0.65
Oil viscosity (mm <sup>2</sup> /s)		5 ~ 1600, Best range: 16~36
Oil temperature (°C)		-25 ~ 103
Oil cleanliness		ISO 4406 20/18/15

## Type Introduction

HM2F	90	N	W	V	N4	D0	B	N	N
①	②	③	④	⑤	⑥	⑦	⑧	⑨	⑩

### Product series

①	Bent-axial piston fixed displacement motor	HM2F
---	--	------

### Displacement

②	Displacement (cc/rev)	90
---	-----------------------	----

### Thread type of ports

③	Thread type of A/B port and T1/T2 port	UNC threads	A
		Metric threads	N

### Direction of rotation

④	Clockwise, Counter clockwise	W
---	------------------------------	---

### Seals

⑤	FKM (Viton rubber: DIN ISO 1629)	V
	NBR (Nitrile rubber :DIN ISO 1629)	N

### Mounting flange

⑥	140-4 ISO 3019-2	N4
---	------------------	----

## Type Introduction

### Input shaft

⑦	W40×2×18×9g DIN 5480	D0
---	----------------------	----

### Port position

⑧	Bottom	B
---	--------	---

### Control

⑨	With	S
	Without	N

### Speed sensor

⑩	With	S
	Without	N

### Section view

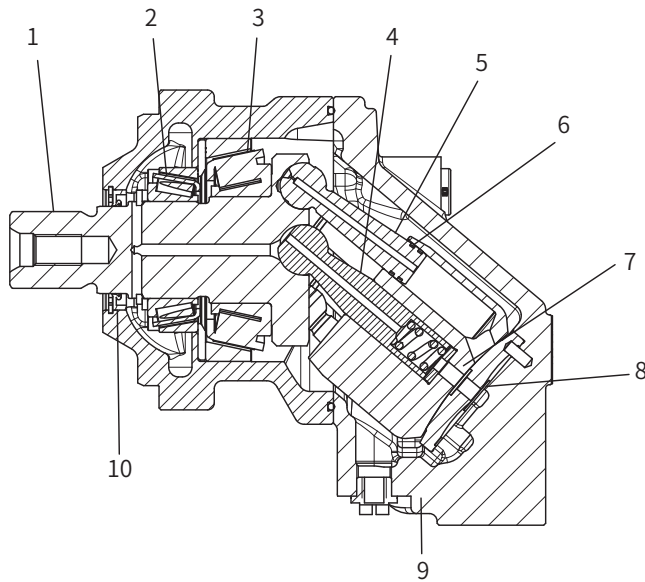

- |                                  |                   |
|----------------------------------|-------------------|
| 1. Output shaft                  | 6. Sealing ring   |
| 2. Tapered roller bearing(small) | 7. Cylinder block |
| 3. Tapered roller bearing(large) | 8. Valve plate    |
| 4. Centering journal             | 9. End cap        |
| 5. Piston                        | 10. Oil seal      |

### Principle

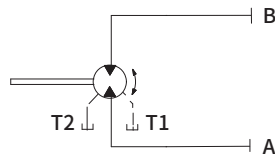

03

# Installation size

## HM2F 90 Installation size

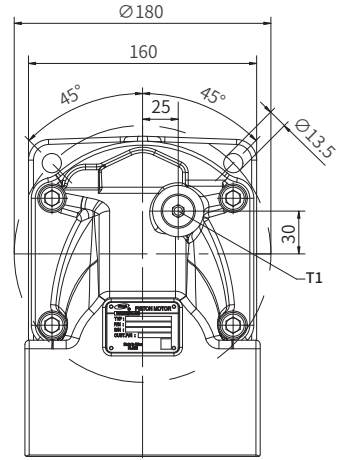
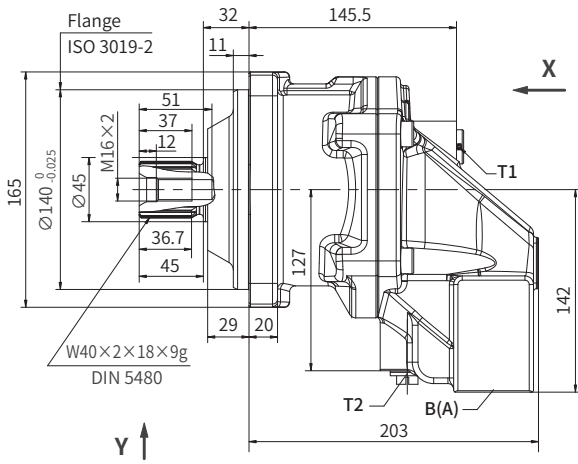

X View

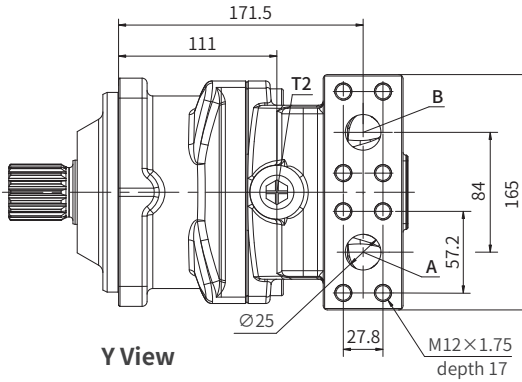

Y View

## Installation size

### • HM2F 90 Direction of rotation and oil flow direction

Installation	Rotation
Flow A → B	Clockwise
Flow B → A	Counter-clockwise

### • HM2F 90 Port details

	Port name	Port size and description	Tightening torque (N·m)
A、 B	Inlet port and Delivery port	SAE J518 DIN 13 1" M12×1.75 (depth 17mm)	130
T1、 T2	Case drain port	DIN 3852 M18×1.5 (depth 12mm)	60

Port	H	D	M
T1	17	∅ 18	M18×1.5
T2	17	∅ 18	M18×1.5

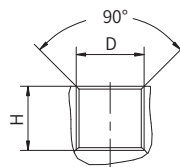

### • HM2F 90 Input shaft type

“A1” type shaft

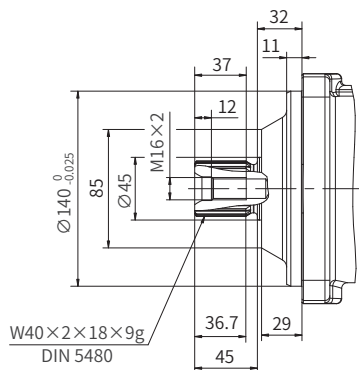

**China**

+86 400 101 8889

**America**

+01 630 995 3674

**Germany**

+49 (30) 72088-0

**Japan**

+81 03 6809 1696



© This brochure can be reproduced, edited, reproduced or transmitted electronically without the authorization of Hengli Hydraulic Company. Due to the continuous development of the product, the information in this brochure is not specific to the specific conditions or applicability of the industry, thus, Hengli does not take any responsibility for any incomplete or inaccurate description.